

The National Space Weather Program

Program Elements

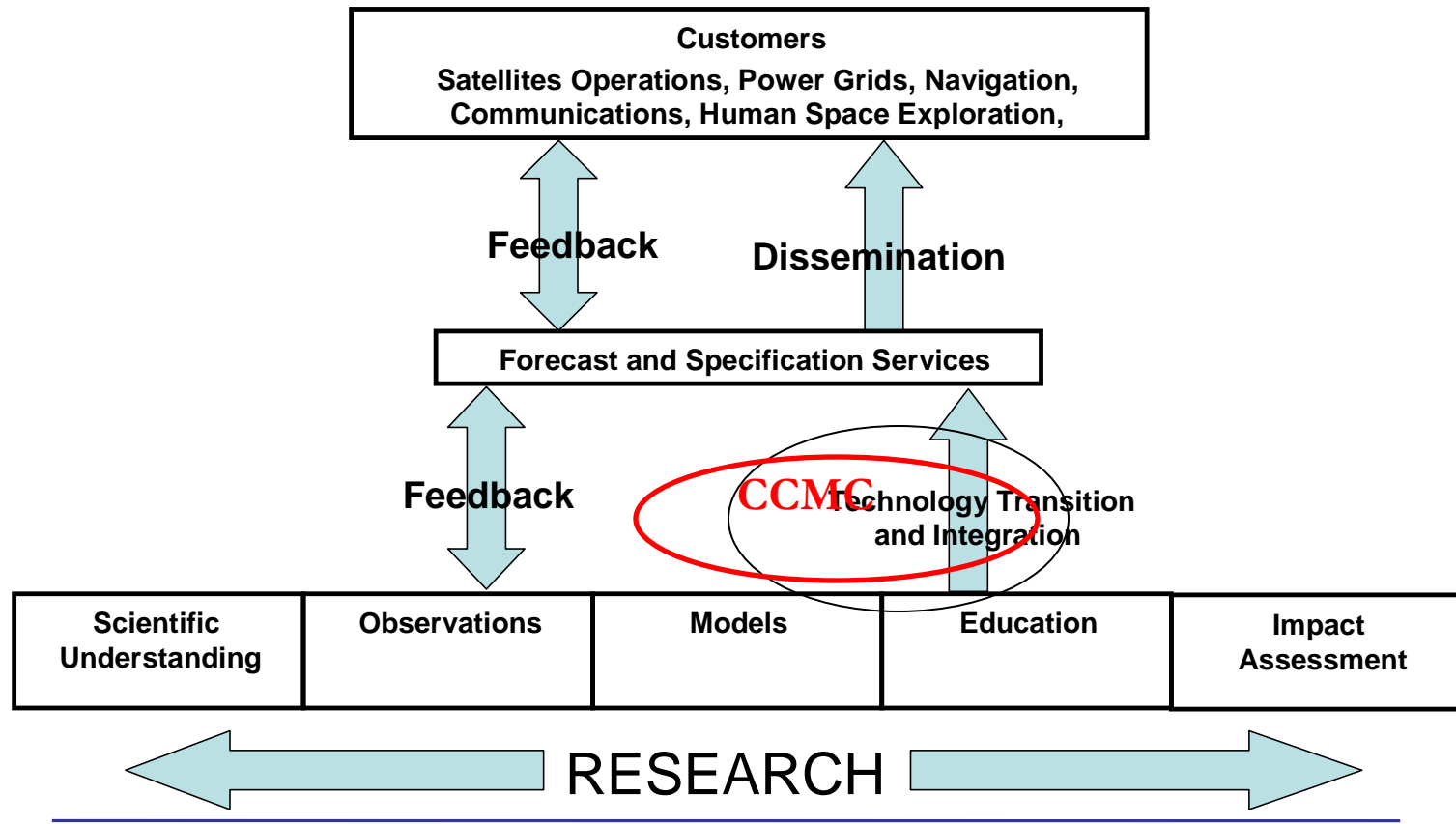

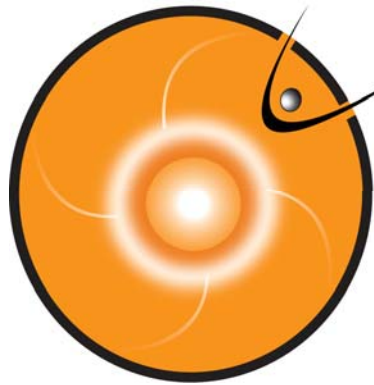

COMMUNITY
COORDINATED
MODELING
CENTER

Director's Report

Michael Hesse

<http://ccmc.gsfc.nasa.gov>

NASA Goddard Space Flight Center

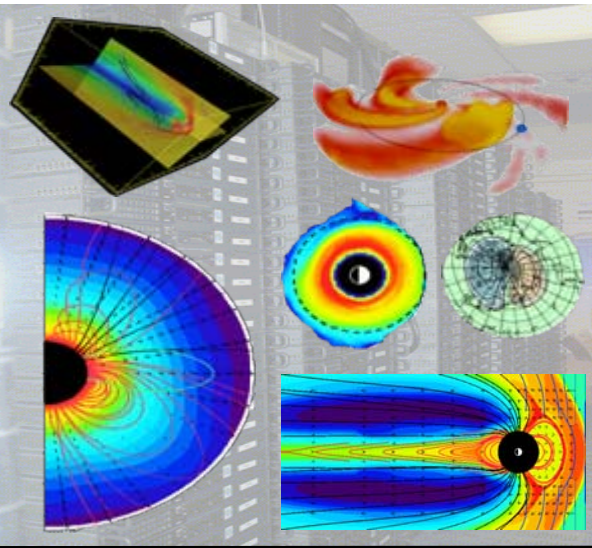

SMD Scientific Research

- **Basic and applied research**
 - All areas of SMD science
 - Data analysis, field campaigns, theory, computing, basic technology, mission concepts, etc.
 - Complete suborbital investigations using sounding rockets, scientific balloons, airborne campaigns
- **Emphasizes NASA relevance**
 - Must further NASA's strategic goals and objectives in science
 - Must require use of space
 - Distinguishes NASA from NSF, DOE, etc.
- **Common mechanisms**
 - Competitive grants via ROSES
 - Open to universities, industry, NASA Centers, other Government agencies
- **Yearly investment totals about \$600 million**

Heliophysics Program Content

	FY09	FY10	FY11	FY12	FY13	FY14
FY10 President Submit	591.6	605.0	672.6	720.5	742.7	762.6
Living with a Star	238.6	212.2	204.6	208.7	230.0	236.6
SDO	20.8	34.1	20.2	18.6	16.3	15.6
RBSP	154.4	137.1	127.9	105.1	22.0	17.3
Science / Testbeds	23.6	20.9	21.4	21.0	21.6	22.1
Solar Probe Plus	18.0	4.0	16.6	36.7	57.8	81.3
Solar Orbiter Collaboration	6.3	8.8	10.7	20.4	91.2	78.2
BARREL / Future / Management	15.5	7.3	7.7	6.9	21.2	22.0
Solar Terrestrial Probes	123.1	143.0	169.1	170.6	160.8	164.3
MMS	94.6	118.6	149.3	148.8	137.5	143.8
STEREO, Hinode	25.5	23.1	18.0	18.0	18.0	18.4
Future / Management	2.9	1.3	1.8	3.8	5.3	2.1
Heliophysics Explorers	31.4	69.4	119.7	158.1	161.3	167.4
IBEX	9.5	6.9	4.5	4.0	4.0	4.0
GOLD	0.5	0.5	10.6	10.9	6.7	0.9
AIM / THEMIS / TWINS / CINDI	8.4	13.5	13.1	12.0	10.0	9.1
Future / Management	13.1	48.5	91.5	131.2	140.6	153.4
Heliophysics Research	195.9	178.6	178.1	183.1	190.6	194.3
R&A	31.0	35.4	38.4	39.1	40.1	41.1
Operating Missions / Data / Modeling	75.2	66.7	65.1	67.9	71.8	72.8
Sounding Rockets	45.1	47.3	48.9	49.7	51.8	53.0
Research Range	32.3	19.2	18.6	19.2	19.6	20.1
GSFC Building / SMD Administrative	12.2	10.1	7.1	7.2	7.3	7.4
New Millenium	2.7	1.8	1.1			

Space Weather Community Modeling Program

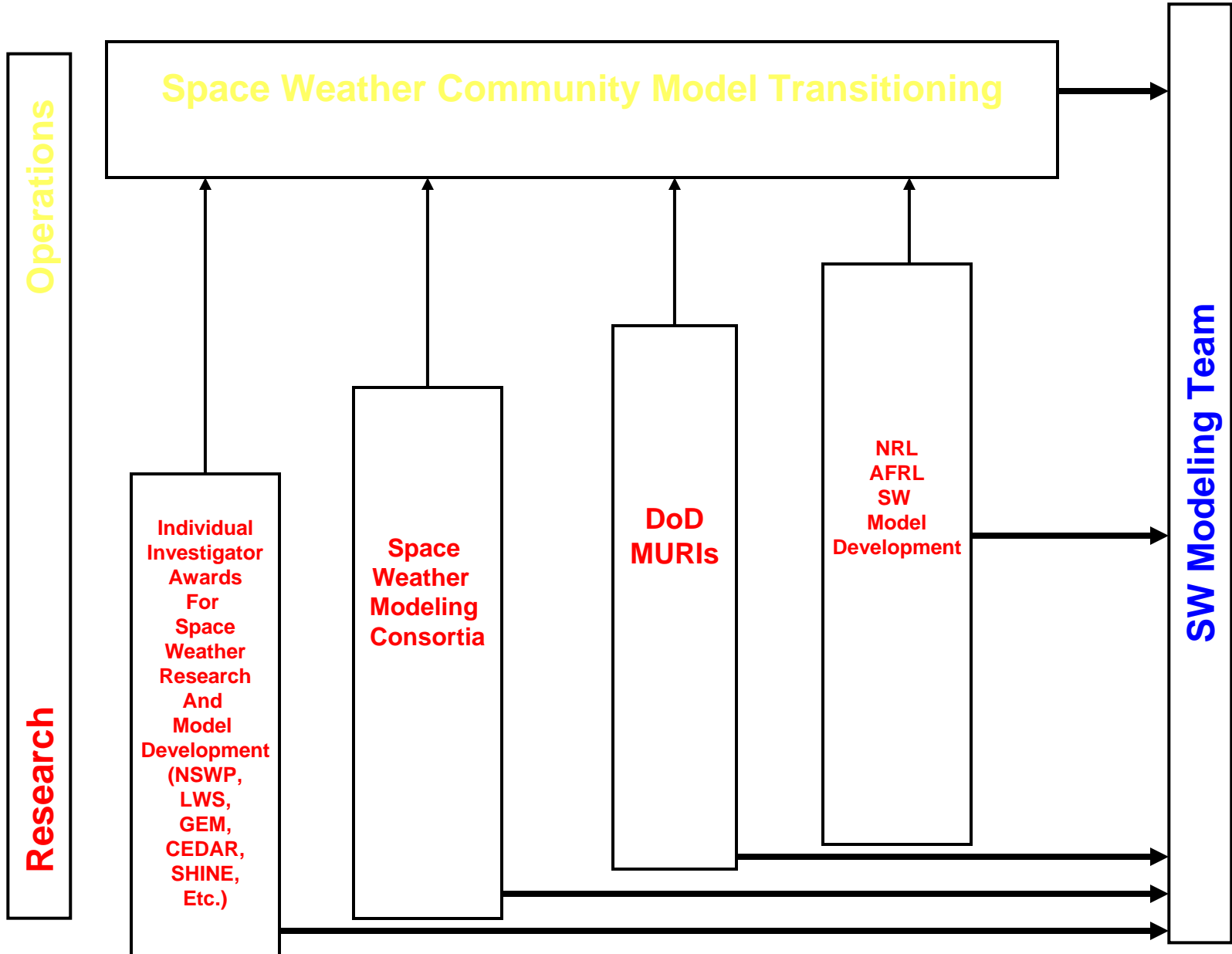

OpenGGCM: Global Magnetosphere

The Open Geospace General Circulation Model:

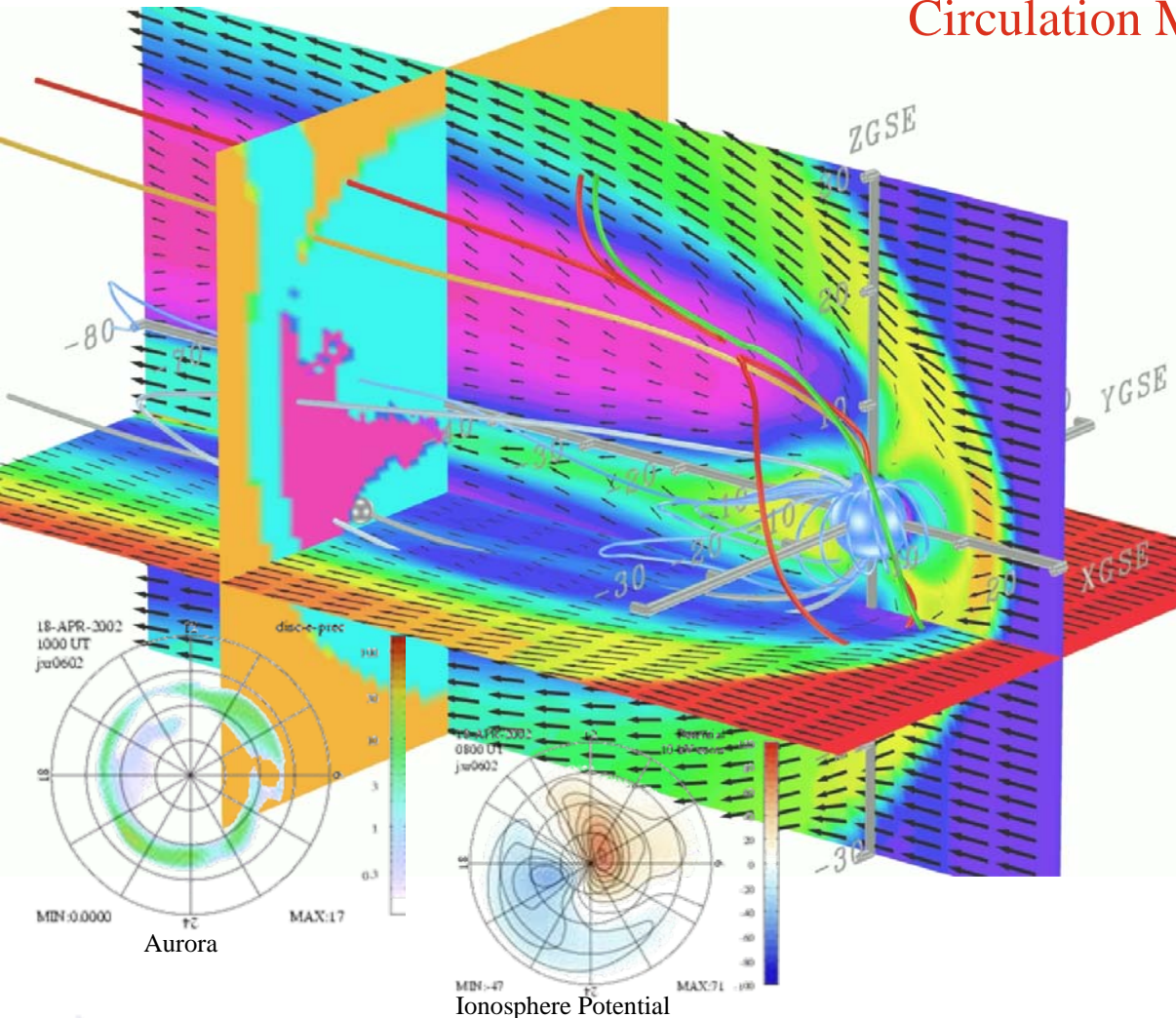

- Coupled global magnetosphere - ionosphere - thermosphere model.
- 3d Magnetohydrodynamic magnetosphere model.
- Coupled with NOAA/SEC 3d dynamic/chemistry ionosphere - thermosphere model (CTIM).
- Coupled with inner magnetosphere / ring current models: Rice U. RCM, NASA/GSFC CRCM.
- Model runs on demand (>300 so far) provided at the Community Coordinated Modeling Center (CCMC at NASA/GSFC).
<http://ccmc.gsfc.nasa.gov/>
- Fully parallelized code, real-time capable. Runs on IBM/datastar, IA32/I64 based clusters, PS3 clusters, and other hardware.
- Used for basic research, numerical experiments, hypothesis testing, data analysis support, NASA/THEMIS mission support, mission planning, space weather studies, and Numerical Space Weather Forecasting in the future.
- Funding from NASA/LWS, NASA/TR&T, NSF/GEM, NSF/ITR, NSF/PetaApps, AF/MURI programs.

Personnel: J. Raeder, D. Larson, W. Li, A. Vapirev, K. Germaschewski, L. Kepko, H.-J. Kim, M. Gilson, B. Larsen, H. Dai, (UNH), T. Fuller-Rowell, N. Muriyama (NOAA/SEC), F. Toffoletto, A. Chan, B. Hu (Rice U.), M.-C. Fok (GSFC), A. Richmond, A. Maute (NCAR)

OpenGGCM Summary

- OpenGGCM use:
 - Tail instability (Siscoe et al.)
 - Ionosphere currents (Vennerstroem et al.)
 - THEMIS support.
 - Metrics.
 - Other science.
- Development under LWS / Strategic Capabilities.
- Development under NSF/PetaApps.
- Other Developments.
- Future Releases (v4.0).

CISM Coupled Model System

MODEL CONNECTIVITY & OPTIONS

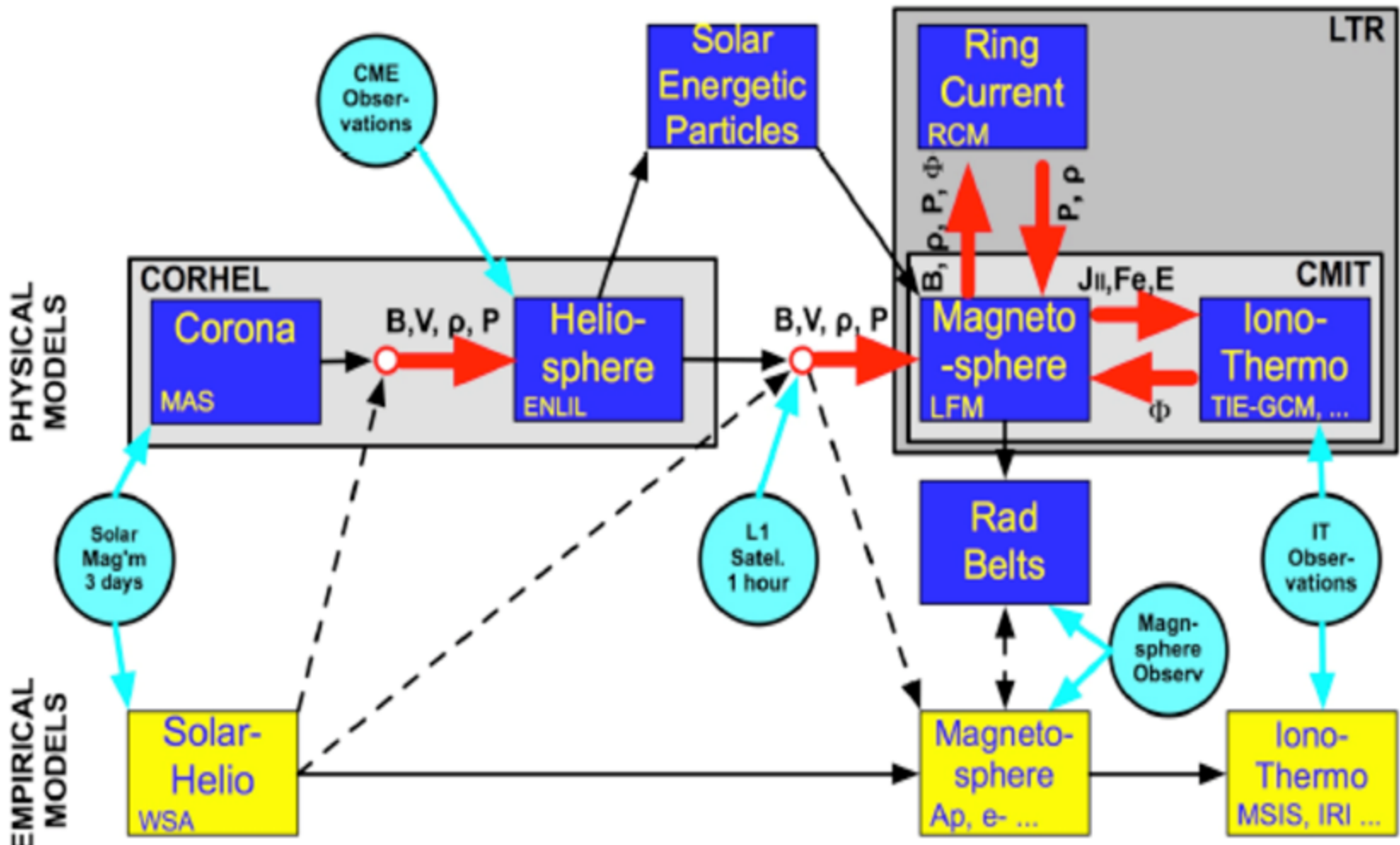

CISM models at CCMC

Model	First Run	# of Runs	Talk
MAS	10/03	62	
CORHEL	6/07	7	Z. Mikic
PFSS	3/04	115	
WSA	4/07	8	N. Arge
ANMHD	2/09	1	
ENLIL	4/05	552	D. Odstrcil
LFM-MIX	?	12	
TIEGCM			S. Solomon
RCM			S. Sazykin

CSEM and CCMC

- Models
 - BATS-R-US was the first model at CCMC (2000)
 - BATS-R-US was the first RoR model at CCMC in 2001
 - BATS-R-US/SWMF is running in an experimental 24/7 real-time mode since 2002
 - SWMF is available at CCMC since 2004
 - SWMF is used for NASA mission support since 2008
- Statistics
 - 1275 RoRs were made with SWMF/BATS-R-US out of 2900 total runs (45%)
 - ~75% of all magnetosphere RoR runs used SWMF/BATS-R-US
- Impact of RoRs
 - ~100 Presentations
 - ~30 Peer reviewed publications
 - 5 Ph.D. dissertations
- CCMC has access to the CSEM CVS repository and there is no “time-lag” between CSEM and CCMC codes.

CSEM/CRASH Capabilities:

Physics

Fluid Equations

- Compressible HD
- Ideal MHD
- Semi-relativistic MHD
- Resistive MHD
- Single-fluid Hall MHD
- Two-fluid Hall MHD
- Multi-species MHD
- Multi-fluid MHD
- Anisotropic pressure
- Heat conduction

Additional Physics

- Multiple materials
- Non-ideal EOS
- Radiation
 - Gray diffusion
 - Multigroup diffusion
- Source terms
 - Gravity, mass loading, chemistry, photo-ionization, recombination, etc...
- Various resistivity models
- Semi-empirical coronal heating
- Alfvén wave energy transport and dissipation
- Self-consistent turbulence

CSEM/CRASH Capabilities:

Numerics

- Time integration Schemes
 - Local time-stepping for steady state
 - Explicit (with Boris correction)
 - Explicit/implicit
 - Semi-implicit
 - Point-implicit
- Grids
 - Block-adaptive tree
 - Cartesian
 - Generalized grids including spherical, cylindrical, toroidal
- TVD Solvers
 - Roe
 - HLLD
 - HLLE
 - Artificial-wind
 - Rusanov
- Limiters
 - Koren (3rd order)
 - MC
 - Beta
- Div(B) control
 - 8-wave
 - Hyperbolic/parabolic scheme
 - Projection
 - Staggered grid (CT)
- Ray tracing
 - Fast & parallel
- Synthetic images
 - White light coronagraph
 - EUV LOS (171Å, 195Å, 284Å)
 - X-ray radiographs
- Tomography